

## Comprehensive assessment of the working efficiency of the destructive working element of the construction machine

Volodymyr Rashkivskiy<sup>1</sup>, Oleksander Teteriatnyk<sup>2</sup>, Olena Shandra<sup>3</sup>

<sup>1, 2, 3</sup> Kyiv National University of Construction and Architecture  
Povitroflotskyi Avenue 31, Kyiv, Ukraine, 03037

<sup>1</sup> [rashkivskiy.vp@knuba.edu.ua](mailto:rashkivskiy.vp@knuba.edu.ua), <http://orcid.org/0000-0002-5369-6676>

<sup>2</sup> [teteriatnyk.oa@knuba.com](mailto:teteriatnyk.oa@knuba.com), <http://orcid.org/0000-0002-9983-0551>

<sup>3</sup> [shandra.oh@knuba.edu.ua](mailto:shandra.oh@knuba.edu.ua), <http://orcid.org/0000-0002-2486-0529>

Received 11.10.2021, accepted 23.11.2022

<https://doi.org/10.32347/uwt.2022.12.1302>

**Abstract** The article uses approaches to the comparison of rock-crushing working bodies based on the use of complex indicators of the quality of construction machines used on construction sites. The use of such indicators is due to the need for constant improvement of existing equipment and the creation of new ones taking into account existing needs. Today, in Ukraine, there is a need for efficient implementation of construction works related to the laying of main pipelines. This, in turn, poses the task of determining the efficiency of performing mechanized earthworks during the laying of engineering networks. Complex indicators are grouped by characteristics. The first group includes indicators of classification, purpose, reliability, manufacturability, standardization and unification, patent law, aesthetics, ergonomics, safety. The second group consists of economic indicators. The third group is defined by indicators of competitiveness. Indicators of the 4th group and above evaluate the main groups of subsystems of machines or complexes of energy and technological purposes.

The need to create competitive earthmoving equipment requires the use of modern constructive solutions and their objective comparison at the design stage. In the course of the study, earthmoving working bodies for laying engineering networks of the type "cone cutter" and "end working body" in the form of a disk were compared. A comparison of the nominal and oscillating modes of operation of the end working body is also proposed. Design features of the working body of the type "cone cutter" and "end working body" are described. The results are summarized in the form of tabular data.



**Volodymyr Rashkivskiy**  
Head of the Department  
of Construction Machinery  
PhD, Ass. Prof.

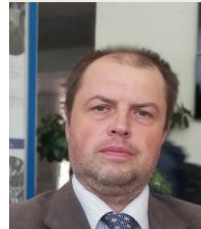

**Oleksander Teteriatnyk**  
Assistant at the Department  
of Construction Machinery



**Olena Shandra**  
Senior Lecturer of the  
Department of Construction  
Technology

The proposed technical solutions open the possibility of variable use of rock-crushing work equipment of construction machines in accordance with the economic requirements and needs of the end user. The effectiveness of using the methods of comprehensive assessment of technical solutions lies in the possibility of their analysis by individual indicators, in combination, as well as when ranking the values of individual indicators according to significance.

**Keywords:** a complex indicator, a trencher, an end-to-end working element, a road cutter.

## INTRODUCTION

Today, on the territory of Ukraine, when performing construction and renovation works, it is necessary to use rock-crushing machines for laying communications, which have the properties of speed, mobility, and the cost of performing the work is relatively low. At the same time, it is often necessary to create new working bodies for construction machines, technological equipment – to develop a work execution plan using effective mechanized equipment and machines [1].

When introducing new designs of machines, it is important to evaluate their effectiveness at the stage of operation. A theoretically and experimentally based optimization objective function is used to evaluate the options for constructive solutions, which consists of indicators determining the efficiency of the designed earthmoving machine. Indicators are divided into groups that evaluate the quality of the technical object, economy and competitiveness [2, 3].

Designs of working bodies, attached equipment, power drives of trenchers for laying engineering communications developed at the Department of Construction Machinery of Kyiv National University of Construction and Architecture in a number of cases allow to effectively perform engineering tasks to ensure the efficiency of technological construction processes [4, 5, 16].

## PRESENTING MAIN MATERIAL

Determining the comprehensive evaluation of the machine at the stage of development of the work execution project allows to avoid possible cost risks and determines the direction of creating a variable database at the work execution site.

For a comprehensive assessment of objects, especially construction machines, it is necessary to carry out their formal separation according to the main indicators that determine their effectiveness [2, 15, 17].

The first group includes indicators: classification; purpose; reliability; manufacturability; standardization and unification; patent law;

technical aesthetics; ergonomic; safety [2, 15, 17].

The indicators are selected based on the requirements of international and national standards and norms, as well as the legislation of the countries in force where the machine is operated.

The second group consists of economic indicators that determine the costs of purchasing a machine (price, transportation, installation, adjustment, etc.), operating costs, energy costs (for fuel, etc.), for paying service personnel, etc [2]

The third group is determined by the indicators of competitiveness – terms of sale (on credit, on the basis of barter, etc.), the level of service and prestige advertising; are evaluated in points by the expert method.

The system of indicators, interconnected with the purpose of the machine and the nature of the technological processes performed, is determined on the basis of the analysis of the integral technical and economic indicator, which compares the costs produced with the effect obtained in the national economy from the use of the appropriate technology and the profit of the consumer. As an integral indicator, reduced specific costs  $z_{\text{ИИТ}} = z/\Pi$ , UAH/m<sup>3</sup> are accepted, where  $z$  is reduced costs, UAH/h;  $\Pi$  – operational productivity, m<sup>3</sup>/h [3, 4]

The stated costs are determined by the formula  $z = S + EK$  UAH/year, where  $S$  – the exact annual costs;  $K$  – capital investments, adjusted to the year by multiplying by the standard efficiency ratio  $E$ . For construction and road vehicles  $E$ , it is accepted as equal to 0.15. The system of generalized private indicators for evaluating the efficiency of the machine is obtained by determining the reduced costs separately for each of the main subsystems of the machine, for example:

energy supply (engines), the costs of which are proportional to the installed capacity of engines  $N$ ;

technological costs that are proportional to the mass of the machine  $G$ ;

life support – (cabin, control elements), the costs of which do not depend on  $N$  and  $G$ ;

costs for labor resources (for the operator and service personnel), dependent on the

weight of the machine and proportional to the number  $n$  of workers servicing it.

Generalized indicator of energy, material intensity and output per person

$$\Pi_N = \frac{Nn}{\Pi_T \Pi}$$

The quality of machine manufacturing is evaluated by the reliability indicator:

$$k = \frac{t_{CEP}}{t_{CEP} + t_{VC} + t_{IPO\Phi}}$$

where  $t_{CEP}$  – average working time of the machine;  $t_{VC}$  – troubleshooting time;  $t_{IPO\Phi}$  – time for preventive measures.

Each of the indicators is in a hierarchical relationship with the others. The parameters and indicators of the lower level are included in the

indicators of the higher level. Moreover, the indicator of the 1st group is appropriate for the evaluation of system and machine complexes, if it is known that the coefficients of specific reduced costs for the compared objects change significantly in the process of developing a new object. Taking into account the difference in the economic, technical, financial and conjunctural policies of the production and operation of earthmoving machines in different countries, it is reasonable to compare machines of different designs on the basis of generalized indicators only between similar machines produced by one country.

The indicator of the 2nd group has the same purpose as the integral indicator of the 1st, but on the condition that for the new object the coefficients of the reduced specific costs for operation and fixed assets do not change significantly in comparison with the

Table 1. Evaluation of the effectiveness

Evaluation group	Indexes		Rationalization and optimization condition	Rating
	Name	General form of record		
1	Specific costs are given	$z_{\Pi IT} = C_{\Pi IT} + Ek$	$z_{\Pi IT} \rightarrow \min$	Integral technical and economic efficiency
2	A generalized indicator of energy intensity and material intensity, attributed to the output of one worker	$\Pi_{NGn} = NGn / \Pi^3$	$\Pi_{NGn} \rightarrow \min$	Generalized technical level on cost savings
3	Generalized indicator of energy and material intensity	$\Pi_{NG} = N_{\Pi IT} / \Pi^3$	$\Pi_{NG} \rightarrow \min$	The same
4	Energy intensity	$N_{\Pi IT} = N / \Pi$	$N_{\Pi IT} \rightarrow \min$	Energy cost savings
5	Material capacity	$G_{\Pi IT} = G / \Pi$	$G_{\Pi IT} \rightarrow \min$	Savings in material costs
6	Production of one worker	$n_{\Pi IT} = \Pi / n$	$n_{\Pi IT} \rightarrow \max$	Labor cost savings
7	Productivity	$\Pi$	$\Pi \rightarrow \max$	Increase in productivity
8	Cycle time and work operations	$t_{\Pi}$	$t_{\Pi} \rightarrow \min$	Duration of work operations
9	Performance indicator	$k$	$k \rightarrow \max$	Machine manufacturing quality and reliability
10	Separate technical parameters	$P, N, G$	$P \rightarrow \min$ , $N \rightarrow \min$ , $G \rightarrow \min$	Improvement of individual parameters

standard It should be used as a base for evaluating the technical level of machines and complexes.

Evaluation of the effectiveness of constructive solutions, which make up a group of indicators of technical significance (Table 1).

The synthesis of this indicator with the coefficients of qualitative indicators of target and restrictive purpose allows to obtain a generalized indicator of the technical level of the system [3, 4].

The indicator of the 3rd group also gives an opportunity to estimate the savings of energy and material costs in the complex.

The indicators of the 4th and 5th groups evaluate the main groups of subsystems of machines or complexes for energy and technological purposes, the 6th – for saving labor resources during the operation of new complexes and machines, taking into account system reliability indicators. The indicator of the 7th group is one of the most important, since all indicators of a higher level can be set only if the productivity value is known. Indicators of the 8...10th groups allow you to determine the quality of the machine with unchanged parameters included in the indicators of a higher level.

Based on the system of the specified indicators, they perform a comparative assessment of the technical level of machines and complexes as a whole, individual subsystems and work processes under average operating conditions and taking into account their probable interpretation, solve the task of improving the organization of product quality management.

Evaluation of the technical solution at the stage of formation of options for constructive solutions is carried out according to the indicators of the 2nd...7th groups or according to one of the indicators of the 8th...10th according to previously specified information. The calculation is performed on the basis of known mathematical expressions that establish a connection between indicators and determining parameters [3, 4].

At the stage of experimental studies, indicators are calculated using physical or combined modeling with large-scale models of new constructive solutions.

Indicators of groups 1...7, which include productivity, are intended to be calculated on the basis of values of theoretical, technical and operational productivity. Due to operational performance, reliability indicators of the designed machine are entered into the calculation (Table 2) [3, 4, 17].

With a variety of parameters, the effectiveness of a new constructive solution is evaluated by a complex indicator

$$k = \sum k_i p_i ,$$

where  $k_i$  – relative  $i$ -th partial indicators of efficiency according to the options of new solutions;  $p_i$  – the weighting factor of the  $i$ -th relative partial efficiency indicator.

Relative partial indicators of efficiency are determined by formulas:

$$k_i = \frac{E_T}{E_H} \text{ with } E_H < E_T; k_i = \frac{E_H}{E_T} \text{ with } E_H > E_T;$$

where  $E_H$  – the value of the  $i$ -th indicator of the new decision option;  $E_T$  – the value of the  $i$ -th indicator of the traditional solution, taken as a benchmark.

The coefficients of the corresponding partial indicators are established by the method of expert evaluations. For approximate calculations,

**Table 2.** Indexes of effectiveness

Indexes	Weighting factor
Technical level :	0,4
qualification	0,016
appointment	0,072
reliability	0,076
manufacturability	0,036
standardization and unification	0,04
ergonomic	0,056
patent law	0,036
technical aesthetics	0,068
Economical	0,34
Terms of sale and serial production	0,26

the values of the weighting coefficients of the partial indicators of the effectiveness of new technical solutions are recommended.

The level of effectiveness of the constructive solution is determined by the efficiency coefficient of the new constructive solution

$$k_H = \frac{E_T}{E_{Hi}},$$

where  $E_{Hi}$  – indicator of the  $i$ -th option of a new technical solution;  $E_T$  – the basic value of the indicator in the group of traditional constructive solutions.

Intensification of earthworks is one of the ways to reduce the energy intensity of their execution. The works [4 – 6] defined the design directions of dynamic work bodies with the functions of intensification of the work process and analytical dependencies regarding the determination of the parameters of auxiliary means of intensification of earthworks.

Fundamental analytical and experimental research made it possible to substantiate a number of fundamentally new provisions for the efficiency of the working processes of rock-crushing machines. The main of these provisions are the following:

1. Formation of oriented high loading speeds. Such a load ensures an increase in the productivity of machines, a decrease in their metal content, and a decrease in the energy intensity of the destruction of the working environment. In addition, the speed loading process is easily controlled.

2. Redistribution of energy flow. The working item must have its own engine, and not receive power from the main engine through systems of various gears and transmissions with low efficiency.

3. Formation of weakened zones in the working environment in front of the working item, which are created due to the accumulation of fatigue deformations during multi-cycle loads

4. Destruction of the working environment by the method of detachment to reduce the energy intensity of the process

5. Reducing the energy intensity of the destruction of the working environment due to the

cutting of the face element without its complete destruction

6. Combining the functions of soil destruction and its transportation in one working item

7. Adaptation of the working body of the earthmoving machine to the peculiarities of the process of development of soil massifs

The end working item (Fig. 1, *b*) is a disk, on the frontal surface of which cutting and throwing elements are installed. Cutting elements are installed according to a modular scheme and form cutting lines, which in turn form cutting modules. Cast elements separate the cutting modules from each other.

When using an end working body to perform trench lines, the geometric parameters of the trench can be changed during the work. In many cases, the lack of variation in the dimensions of the trench limits the use of specific earthmoving equipment, which is excluded in our case - in the process of work, you can change the position of the working item relative to the machine, and if necessary, change the profile of the trench.

The intensification of the work process in the proposed case occurs due to the additional destruction of the work environment. In the design of the cone cutter (Fig. 1, *a*), additional destruction is performed due to the gas intensifier, the oriented gas nozzles of which direct a stream of compressed air at certain time intervals, which additionally loosens the soil. In Fig. 1, *b* shows the design of the end working element for the intensification of the work process, which uses peripheral additional mechanical working bodies that forcibly rotate around their axis and destroy the upper layer of the soil massif [9, 16 – 18].

The values of the coefficients are determined for the operation of a excavator with an end working element with a disc diameter 0,6 m, road cutter. The weight of the machine without the working element – 6,3; attachment equipment – 0,7; end working element – 0,15 т. It is assumed that the basic equipment is always ready for work, i.e.  $k_T = 1$ .

The proposed system of indicators allows you to objectively evaluate the efficiency of the trencher with the end working body according to natural indicators. In terms of value, it is proposed to determine the efficiency according to the existing indicator of

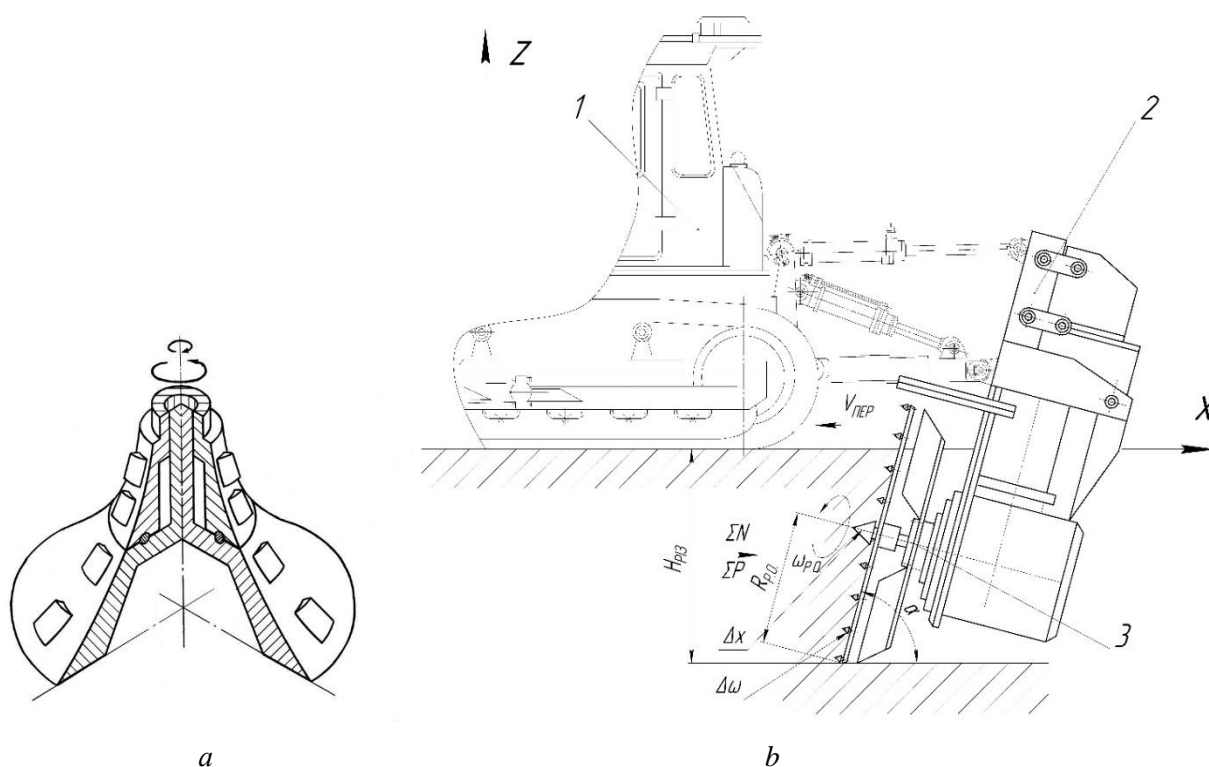

**Fig. 1.** The destructive working body of the construction machine:  
a – road cutter; b – end working body

reduced specific costs according to the known methodology [2, 8, 15, 17].

The new low-energy working body of the "cone cutter" type (Fig. 1, a) consists of two parts: the upper and lower cones, which rotate in opposite directions. The condition for ensuring the directional stability of the machine is the equality of the torques of the upper and lower cones of the working body from the cutting resistance forces of the working environment.

The above construction has the following advantages when working in strong soils: combining cutting and transporting soil with one working body, which reduces the metal and energy consumption of the machine; thanks to the concentric placement of cutting and metal elements (the absence of their mutual overlap in radial directions), the soil is destroyed by cutting with the formation of rings, and not over the entire area of the slaughter, which reduces the energy intensity of the process; between cutting elements, cutting and throwing elements from different circles with a central element, common stress areas are formed, which reduces the effort and energy intensity of soil destruction; due to the absence of single-radial

cutting lines, non-simultaneous introduction of cutting and cutting-casting elements into cutting is ensured, which reduces the dynamics of the process [19, 20].

Due to its features, the conical cutter works even when hard inclusions hit the cutting and casting elements, which are also thrown outside the trench.

In work [5], approaches to the design of an impulse hydraulic drive are defined, thanks to which, for each individual dynamic working item, it is possible to design a hydraulic scheme that will ensure the maximum possible adaptation of the working item and its working effort during soil development.

In Fig. 2 shows the hydraulic circuit, which provides a follow-up pulse supply to the power motors 10 and 16. The provision of feedback is implemented by synthesized technical means that do not affect the speed of the system as a whole.

The maximum reduction in energy consumption of the earthmoving machine can be achieved by adapting its working body to soil conditions during soil development (Table 3).

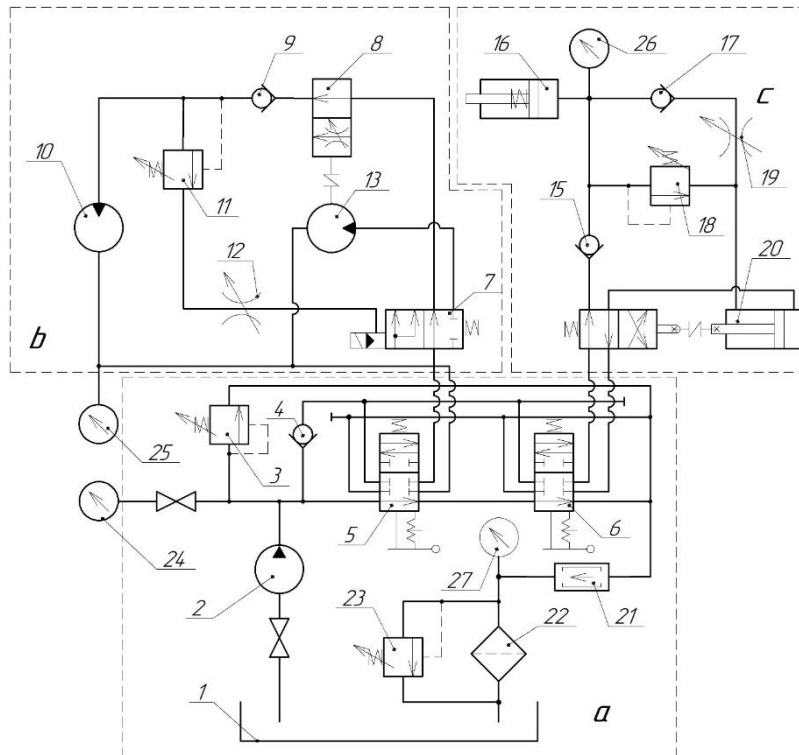

**Fig. 2.** Diagram of hydraulic drive with feedback: *a* – power part; *b* – part of controlling the main circular movement of the disc working item; *c* – part of controlling the longitudinal linear movement of the disc working item. 1 – tank with liquid; 2 – pump; 3 – bypass valve; 4, 9, 15, 17 – check valve; 5 – block control distributor *b*; 6 - block control distributor *c*; 7 – control distributor of the oscillating mode of movement of the disc working item; 8 – oscillation generator; 10 – drive motor of circular oscillating motion; 11, 18 – control valve; 12, 19 – throttle; 13 – drive motor of the oscillation generator; 14 – distributor for controlling the linear oscillating mode of the disc working item; 16 – engine of linear oscillating movement; 20 - drive motor of linear oscillating movement; 21 – compensator; 22 – filter; 23 – safety valve; 24, 25, 26, 27 – manometer

The use of neural networks allows solving the most important problem of evaluating machine performance with the automated creation of a computer model of the efficiency of work processes [12].

To develop an adaptive working body, the dynamic characteristics of the machine, the working body, the attachment and the physical and mechanical properties of the developed environment were analyzed.

**Table 3.** Parameters comparison results

№ п/п	Indicator	Marking	Road cutter	End working body	
				NON Pulse mode	Pulse mode
1	Mass, kg·10 <sup>3</sup>	<i>G</i>	61,2	6,1	6,2
2	Power, kW	<i>N</i>	270	32	27
3	Productivity, m <sup>3</sup> /h	<i>Π</i>	630	90	90
4	Theory Productivity, m <sup>3</sup> /h	<i>Π<sub>T</sub></i>	504	72	72
5	Material capacity, kg·h/m <sup>3</sup>	$M = G / \Pi_T$	121	84,7	86,1
6	Energy intensity, kW·h/m <sup>3</sup>	$e = N / \Pi_T$	0,53	0,44	0,375
7	General indicator of saving material resources	$\Pi_{NG} = NG / \Pi_T^2$	0,065	0,037	0,032

The recommended ratios make it possible to determine the limits of the rational use of a trencher with an end working body and a traditional machine, the average power of the installed engines, the number of performed operations and the ratio of the number of workers servicing the respective machines.

To determine the effectiveness of the use of the end working body of the trencher, a comparative analysis of earthmoving machines was carried out according to 7 indicators.

## CONCLUSIONS

1. A comparative analysis of earth-moving machines showed that with the formation of forced oscillations on the working body, some indicators of the work process improve.

2. In the case of using the same end working body in the form of a disc, the overall indicator of saving material resources improves by more than 10%, which gives reason to talk about the prospects of further development in the direction of work intensification process of trenchers.

## REFERENCES

1. **Sharapa S.P., Tonkacheiev H.M., Lepska L.A.** (2019). Methodology of construction technology. Education manual, Kyiv, KNUCA, 220 (in Ukrainian).
2. **Leonid Khmara** (2020). The basic system of indicators for the technical and economic evaluation of the efficiency of earthmoving machines with innovative working bodies. Visnyk KhNADU. KNADU, 5-2 (in Ukrainian) <https://doi.org/10.30977/BUL.2219-5548.2020.88.2.5> (in Ukrainian).
3. **Khubka V.** (1987). Theory of technical systems. Trans. from Germany, Moskow, Myr, 208 (in Russian).
4. **Horbatiuk Ye.V.** (2006). Creation of the working body of the earthmoving machine with oriented flows of soil removal. Abstract of the candidate of tech.sciences /05.05.04, PDPA, Dnipropetrovsk, 19 (in Ukrainian).
5. **Rashkivskyi V.** (2008). The end working item of the trencher with controllable force parameters. Abstract of the candidate of tech.sciences, 05.05.04, Kyiv, KNUCA, 20 (in Ukrainian).
6. **Pelevin L.Ie., Rashkivskyi V.P.** (2005). The end working item of the earthmoving machine. Patent Ukraine 5595U, Bul.3, 15.03.2005 (in Ukrainian).
7. **Abrashkevych Yu.D., Pelevin L.Ie., Rashkivskyi V.P., Riabchik Ye.L.** (2009). Peculiarities of optimization of the mechanized section on the construction site. Girnichi, budivelni, dorozhni ta meliorativni mashini, Vol.73, Kyiv, KNUCA, 59-61 (in Ukrainian).
8. **Sukach M.K., Ryzhakova L.M., Chernyshev D.O., Ivakhnenko I.S.** (2020). Basics of technology transfer: textbook. Kyiv, TsP Kompyrnt, 318. ISBN 978-617-7748-90-7 (in Ukrainian).
9. **Pristailo M., & Marchuk, K.** (2019). Innovative ways to improve construction equipment given the needs of the modern construction industry. Girnichi, budivelni, dorozhni ta meliorativni mashini, Vyp.94, 35-41 (in Ukrainian) <https://doi.org/10.32347/gbdmm.2019.94.0301> (in Ukrainian).
10. **Prystailo M.O., Marchuk K.V.** (2018). Forecast of growth in demand for construction equipment in the conditions of modern construction Build-Master-Class-2018. International scientific-practical conference of young scientists, 28-30 November, 2018, Proceedings, Kyiv, KNUCA, 332-333 [https://www.bmc-conf.com/download/programm\\_articles.pdf](https://www.bmc-conf.com/download/programm_articles.pdf) (in Ukrainian).
11. **Gorbatyuk Ie.V.** (2022). Modeling the movement of the base ripper tractor in construction. Modern research in world science. Proceedings of the 2nd International scientific and practical conference. SPC, Lviv, 358-362, ISBN 978-966-8219-86-3, <https://sci-conf.com.ua/wp-content/uploads/2022/05/MODERN-RESEARCH-IN-WORLD-SCIENCE-15-17.05.22.pdf> (in Ukrainian).
12. **Gorbatyuk I., Pelevin L., Terentyev O. & Svider'ky A.** (2021). Research of working bodies a continuous action earthworks machines. Girnichi, budivelni, dorozhni ta meliorativni mashini, Vyp.98, 45-54. <https://doi.org/10.32347/gbdmm2021.98.0402> (in Ukrainian).
13. **Osypov V.Yu.** (2010). Recurrent neural network with controlled synapses. Information technologies. No.7, 43-47.
14. **Romasevych Y., Loveikin V., Shevchuk O.** (2021). Identification and Optimal Control of a Dynamical System via ANN-based Approaches, 2021, IEEE 2nd KhPI Week on Advanced Technology (KhPIWeek), Kharkiv, Ukraine, 2021, 83-87, <https://doi:10.1109/KhPIWeek53812.2021.9569976>.



15. Loveikin V., Romasevich Yu., Krushelnytsyi V. (2012). *Mechatronic: navch. posib.*, Kyiv, 355 (in Ukrainian).
16. Fomin A., Garkavenko O., Kostenyuk O., & Teteriatnyk O. (2019). Features of destruction of work environments at information and co-entropy of work processes of construction equipment. *Girnichy, budivelni, dorozhni ta meliorativni mashini*, Vyp.94, 42-50 <https://doi.org/10.32347/gbdmm2019.94.0401> (in Ukrainian).
17. Nazarenko I., Smirnov V., Pelevin L., Fomin A., Sviderskyi A., Kostenyuk O., Ruchynskyi M., Dedov O., Garkavenko O., Martynyuk I. (2013). Fundamentals of the theory of movement of earthmoving and compaction machines of the building industry with time-controlled optimal parameters. Kyiv, MP Lesia, 320 (in Ukrainian).
18. Pelevin L., Karpenko M., Lavryk S., Shcherbyna (2014). Reducing the energy intensity of soil development with the tip of the loosener. *Girnychi, budivelni, dorozhni ta melioratyvni mashyny*, Vyp.84, 65-68 [http://nbuv.gov.ua/UJRN/gbdmm\\_2014\\_84\\_10](http://nbuv.gov.ua/UJRN/gbdmm_2014_84_10) (in Ukrainian).
19. Abrashkevych Yu., Machyshyn H., Marchenko O. (2019). Force analysis of the parameters of manual machines when working with cut-off abrasive reinforced wheels. *Promyslove budivnytstvo ta inzhenerni sporudy*, Vyp.2, 38-47 (in Ukrainian).
20. Abrashkevich Y., Machyshyn H., Marchenko O., & Komotska S. (2021). Mechanized processing of building equipment by abrasive working bodies. *Girnichy, budivelni, Dorozhni ta meliorativni mashini*, Vyp.97, 36-46 <https://doi.org/10.32347/gbdmm2021.97.0302> (in Ukrainian).

### Комплексная оценка эффективности работы породоразрушающего рабочего органа строительной машины

*Volodymyr Rashkivskyi, Oleksander Teteriatnyk, Olena Shandra*

**Аннотация.** В статье использованы подходы к сравнению породоразрушающих рабочих органов на основе использования комплексных показателей качества строительных машин, используемых на строительных площадках.

Применение таких показателей обусловлено необходимостью постоянного усовершенствования существующей техники и создания новой с учетом существующих потребностей. На сегодняшний день в Украине существует необходимость эффективного выполнения строительных работ, связанных с прокладкой магистральных трубопроводов. Это в свою очередь ставит задачу для определения эффективности выполнения земляных механизированных работ при прокладке инженерных сетей. Комплексные характеристики группируются по признакам. Первая группа включает классификационные показатели, назначения, надежности, технологичности, стандартизации и унификации, патентно-правовые, эстетики, эргономики, безопасности. Вторая группа состоит из экономических характеристик. Третья группа определяется показателями конкурентоспособности. Показатели 4-й группы и выше оценивают основные группы подсистем машин или комплексов энергетического и технологического назначений.

Необходимость создания конкурентоспособной землеройной техники обуславливает на проектном этапе использовать современные конструктивные решения, объективное сравнение. В ходе исследования сравнительно землеройные рабочие органы для прокладки инженерных сетей типа конусная фреза и торцевой рабочий орган в виде диска. Предложено сравнение номинального и колебательного режимов работы торцевого рабочего органа. Описаны конструктивные особенности рабочего органа типа "конусная фреза" и "торцевой рабочий орган". Результаты сведены в виде табличных данных.

Предложенные технические решения открывают возможности вариативного использования породоразрушающего рабочего оборудования строительных машин в соответствии с экономическими требованиями и потребностями конечного потребителя. Эффективность использования методов комплексной оценки технических решений заключается в возможности их анализа по отдельным показателям, в сочетании, а также при ранжировании значений отдельных показателей в соответствии со значимостью.

**Ключевые слова:** комплексный показатель, траншекопатель, торцевой рабочий орган, дорожная фреза.